



Using the LH1525 and LH1526 (Dual) Solid State Relay (Appnote 64)

Description

The LH1525 solid state relay (SSR) combines the latest high-voltage integrated circuit technology with an intelligent circuit design to provide an extremely versatile SSR. The LH1525 is able to achieve this versatility by combining low turn-on current with fast switching speed. With standard SSRs, low turn-on current provides slow switching speed. Likewise, high switching speed requires substantial LED drive current. The LH1525 provides a fast switching speed at a much lower drive current. For applications where minimal power dissipation is critical, the LH1525 provides the low turn-on current available in an optically coupled solid state relay.

The LH1525 can be used to minimize power dissipation in battery powered applications or in applications where power management is a concern. It can be used in instrumentation applications where fast switching speed is critical. Or it can be used in telecom applications where its robust current-limit circuitry will protect the relay from lightning and other fault conditions commonly present on telephone lines.

Minimizing Power Dissipation

Figure 1 plots switch load current versus ambient temperature. The amount of LED forward current (I_F) required for switch operation is based on these parameters. If power dissipation is the only concern, select the lowest LED drive current curve that encompasses your load current and ambient operating temperature design window. A given LED forward current will support the operating area below and to the left of the curves. Extrapolate forward current values between 300 μ A and 1 mA as required. If switching speed is also a concern, refer to the next section.

LED Drive Current vs. Switching Speed

The LH1525 can provide switching speeds from as slow as 3 ms to as fast as 100 μ s. Switching speed performance is dependent upon the magnitude of LED drive current used. This application note addresses three areas of operation of turn-on speed and turn-on current. Turn-on speed is the time it takes for the contact to close after current is applied to the LED. Turn-on current is the amount of current required through the LED to sustain a given load current.

The graph in Figure 2 plots LED drive current versus turn-on speed. It has been segmented into these three areas of operation. Very low turn-on current,

slow speed performance is desirable for some battery powered applications and also telecom applications. Low turn-on current, moderate speed performance is suitable for a variety of applications where both speed and power consumption are critical. In instrumentation applications where every microsecond counts, high-speed performance using high turn-on current would be a logical choice.

Very Low Turn-On Current, Slow Switching Speed

LED drive currents between 0.3 mA to 1.5 mA are required to keep switching speeds at 1 ms or more. This slow speed operation is desirable in telecom applications due to the way the relay's current limit circuitry responds to a lightning surge. The LH1525, like many other Vishay Form A SSRs, has integrated current-limiting circuitry. When an SSR is directly connected to a telephone line (e.g., switch hook or ring/test access in a PBX or central office) and high current transients occur from lightning, the current-limit circuit will operate to protect the relay. For a large transient, as those specified by various regulatory agencies, the current-limit circuit will shut down the relay with sub microsecond speed. While the relay is off the power from the lightning dissipates in a transient voltage suppressor. The relay remains off for the duration of one turn-on period. It is important that this off period be long enough to allow the lightning wave to subside. An off period of 1 ms or greater provides the most robust solution. To achieve 1 ms or slower at room temperature, 1.0 mA to 1.5 mA of LED forward current should be used. Refer to Figure 1 to obtain an adequate LED current value for elevated temperature operation.

Another advantage that SSRs bring to this solution is noise-free operation. SSRs will not be a source of acoustical noise and will not generate transients during closure.

Low Turn-On Current, Moderate Switching Speed

LED drive currents between 3.0 mA to 5.0 mA provide nominal switching speeds better than 500 μ s. This fast switching speed is desirable in many data acquisition or instrumentation systems where scanning time needs to be minimized. Most optically coupled MOSFET relays require 5 mA to 10 mA of LED drive for operation at elevated temperatures. The lower drive currents required for the LH1525 minimizes power consumption of the relays. This is very desirable in battery-powered equipment or in large multi-

plexed relay systems where power management is a concern. Of course another advantage the SSR brings to these applications is that no extra settling time is required since there is no contact bounce.

High Turn-On Current, High Switching Speed

LED drive currents above 8 mA provides typical switching speeds below 200 μ s. This current can be provided as a steady-state current or as a current pulse from an RC peaking network. Note that with high LED drive currents the turn-off time will actually exceed the turn-on time. Depending on temperature, turn-off time will run between 200 μ s to 300 μ s with LED drive currents above 8 mA.

Testing and Temperature Variation

The previous discussions referred to typical LH1525 speed performance and 25 $^{\circ}$ C ambient operation. The LH1525 is tested for a maximum turn-on time of 800 μ s with 5 mA of LED drive and a turn-off time of 400 μ s. If maximum speed is critical to a design, these worst-case test limits must be used. Figures 3 and 4 provide LED drive current versus speed graphs for the extreme temperatures as well as room ambient. Use this data to estimate performance at extreme temperatures.

Input Control

If you're familiar with our parts and commonly evaluate their performance using a curve tracer (step generator sourcing current to LED, relay outputs tied to collector and emitter) you may notice that the part is difficult to turn off. Using the 1 mA scale from the step generator may still source microamps of leakage current even when the dial is turned to zero. You'll need to select a lower range like the 50 μ A range to fully turn the relay off.

You will not experience any difficulty in actual use, however, if your logic circuit provides an adequate pull-up voltage.

The LH1525 is designed with highly sensitive photo-detection circuits which will detect even the most minute currents flowing through the LED. The relay typically turns on with only 120 μ A of LED drive at room temperature. At elevated temperatures only 1 mA or 2 mA of LED drive is required to turn the relay on. Leakage current must be considered when designing a circuit to turn on and off these relays.

Figure 5 shows a typical logic circuit for providing LED drive current. R1 is the input resistor which limits the amount of current flowing through the LED. For 5 V operation, a 2700 Ω resistor will limit the drive current to about 1.4 mA. Where high-speed actuation is desirable, use a lower value resistor for R1.

R2 is an optional pull-up resistor which pulls the logic level high output (V_{OH}) up towards the V_S potential. The pull-up resistance is set at a high value to minimize the overall current drawn from V_S . The primary purpose of this resistor is to keep the differential voltage across the LED below its turn-on threshold. LED dropout voltage is graphed versus temperature in the Typical Performance Characteristics section of the designer's guide. Many applications will operate satisfactorily without this pull-up resistor. In the logic circuit of Figure 5, the only path for current to flow is back into the logic gate. Logic leakage is usually negligible. Each application should be evaluated, however, over the full operating temperature range to make sure that leakage current through the input control LED is kept to a value less than the minimum LED forward current for switch turn-off specification.

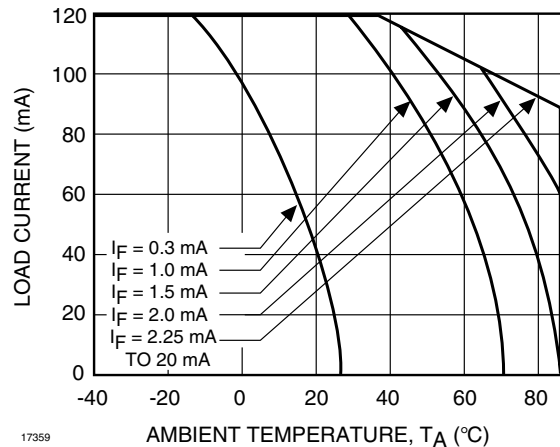

Figure 1. SSR recommended operating conditions

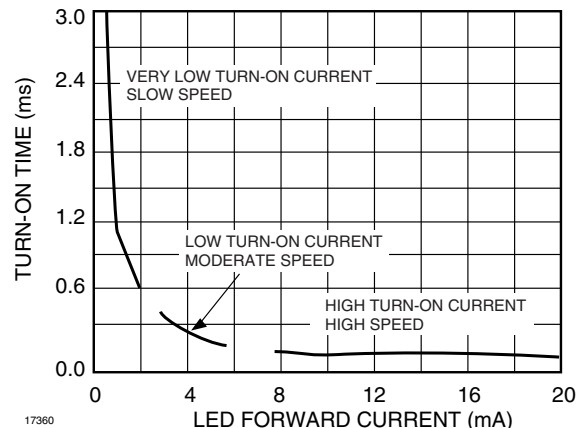
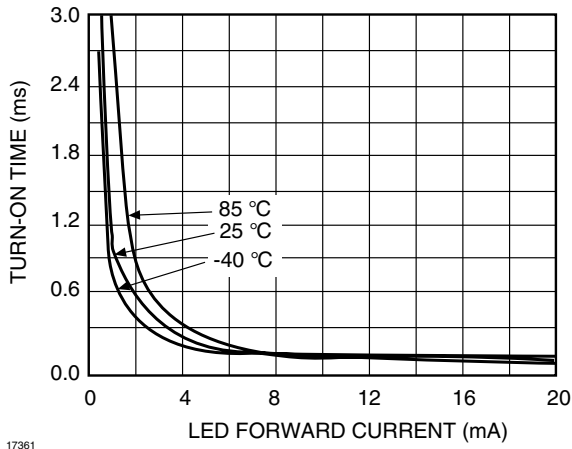

Figure 2. Turn-on time vs. LED current



17361

Figure 3. Typical turn-on time vs. LED current

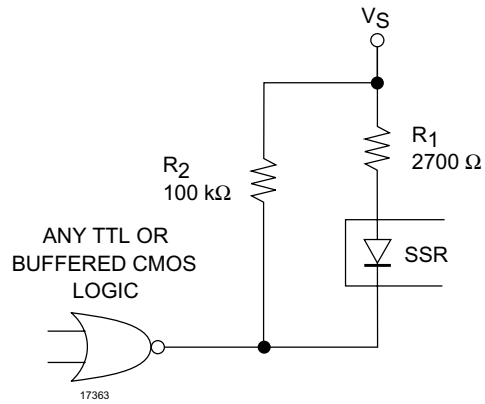
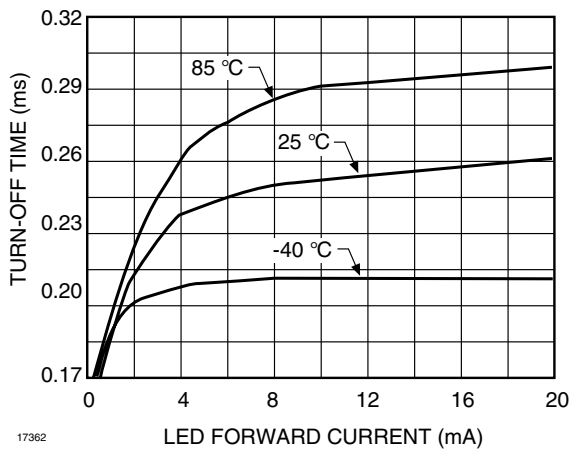

Figure 5. Input control circuit



17362

Figure 4. Typical turn-off time vs. LED current